



FS 1.1LT
Bucket technical characteristics

Dimensions

D1: 109 mm

D2: 98.5 mm

H: 158.6 mm *without the lid*

Deviation ± 1mm

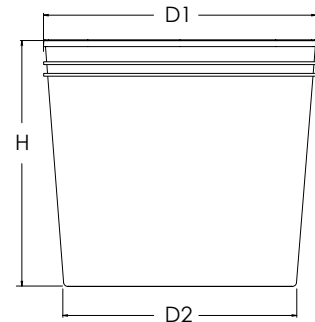

Other elements

Capacity (LT)	Volume to rim	0.965 LT
Net weight / Deviation (±2.5%)	66 gr	
Buckets packaging	Pallet 1008 pcs	
Decoration	IML Label	339X144,80 mm



Lid technical characteristics

FS 1.1LT

Dimensions

D: 111.4 mm

H: 17.3 mm

Deviation ± 1mm

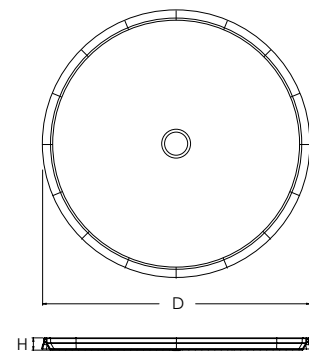

Other elements

Lid weight (gr) Deviation (±2.5%)	22 gr
Lid packaging	Carton box 840 pcs

USEFUL STORAGE INFORMATION: To preserve the quality of this product, it is recommended that it be stored in its original packaging, away from any source of local heat and moisture, away from direct sunlight (below 30°C) and dry conditions. It is recommended that the product be allowed to reach operating temperature 24 hours before use.

RAW MATERIAL: Polypropylene (PP)



ISO 22000/ISO 9001/FSSC 22000

